

Thank you for purchasing an ATV/Motorcycle computer. This manual is specifically designed for the ACE-290X series. The ACE-290X series has 2-6 LED indicators. Different models have different LED indicators. You may find the photo above has a set of LED indicators different from your computer; the photo is for reference only.

PANEL DESCRIPTIONS

1. Tachometer Scale
2. Bar Tachometer
3. 1st row: Temperature meter.
4. 2nd row: Other functions display
5. RESET Button
6. MODE Button
7. LED indicator symbols

	Left-Direction Indicator/Green		Engine Oil / Red
	Main-Beam Headlamp/Blue		Neutral Gear /Green
	Right-Direction Indicator/Green		Reverse Gear /Red
	Hazard Warning/ Red		Drive Gear /Green
	Parking/Green		Engine Coolant Temperature/ Red
	Direction Indicator/Green		Rear Fog Lamp/Amber
	Trailer Flashers/Green		Engine "Not In Use"/Red

FEATURES

- LCD has two rows digital and one analog bar-graphic tachometer displays, with blue LED backlight.
- Temperature range is suitable for both water and oil temperature.
- Tachometer with adjustable engine rotations per signal is suitable for most engines.
- Tachometer signal can pick up from either CDI or ignition-coil.
- Adjustable shift RPM warning and temperature warning.
- Includes RPM sensor, temperature sensor, bracket and fitting accessories.
- Vibration (8G) and mechanical shock (100G) tested.
- Water resistant tested 100%.
- EMI/EMS tested.

SPECIFICATIONS

FUNCTIONS	Symbol	SPECIFICATIONS	INCREMENTS	ACCURACY
Bar Tachometer		500-12,000 rpm	500 rpm	
Digital Tachometer	RPM	100-19,900rpm	100 rpm	
Shift Warning	RPM	100-19,900rpm	100 rpm	
Maximum Tachometer	MAX RPM	100-19,900rpm	100 rpm	
Temperature Meter		+40°C-150°C	1°C	+/- 1°C
Maximum Temperature		+40°C-150°C	1°C	+/- 1°C
Riding Time	RT	0:00:00"- 99:59:59"	1 Second	+/- 50PPM
Total Time	TT	9999H59'	1 Minute	+/- 50PPM
Clock		23H59'	1 Minute	+/- 50PPM

Power Input DC 12V
 Temperature Sensor Thermo Sensor
 Tachometer Input CDI or Ignition Coil signal
 Operation Temperature -10°C - +80°C
 Storage Temperature (Inner housing) -25°C - +85°C
 Dimensions ϕ 64mm / H 40mm

FUNCTIONS DESCRIPTIONS

1. Bar Graphic Tachometer :
Tachometer ar graphic displays up to 12,000 RPM.
2. Radiator or Engine Oil Temperature: +40°C ~+150°C.
3. RT (Engine Running Timer): It counts engine running time from last Reset operation.
4. TT (Engine Total Running Timer): Calculates total operation time from the beginning of the Engine. The data is stored in memory, even when power is removed.
5. MAX RPM & Temperature: Displays highest RPM & Temperature from last reset operation.
6. Shift RPM Warning:
Function enables you to set up a RPM shift warning. Bar-graphic tachometer flashes when RPM reaches pre-set value , and stops flashing after you shift gear.
7. 12/24 Hour Clock:
Displays 12- or 24-hour current time.

BUTTON OPERATIONS

MODE BUTTON

1. Press the MODE button to move all functions in loop sequence from one function screen to another when the RPM sensor does not detect any signal input.
2. LCD screen will automatically revert to Temperature Meter and Tachometer screen during operation movement, if no button usage for 30 seconds

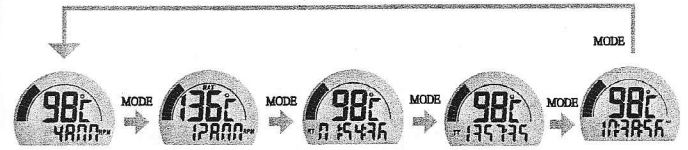

RESET BUTTON

1. Press MODE button to the desired screen then press RESET button for 2 seconds to reset Maximum Temperature and RPM and RT data from stored values to zero individually.
2. TT and Clock data cannot be reset.



SHIFT RPM WARNING OPERATION

1. Press MODE button to the RPM screen; pull on the throttle until the desired shift warning RPM displayed.
2. Press RESET button to confirm and set up the shift warning RPM.
3. Bar-graphic tachometer will flash to warning you shift gear.
4. Operate items 1 & 2 to readjust the shift warning RPM.



Push RESET Button to Set Up The Shift RPM Warning

RPM, Temperature & Numbers of Engine Rotation SET UP

1. Setup operations include 12/24 hour clock, shift warning RPM, Temperature warning and numbers of engine rotations per signal. These must be set up step by step. The computer will automatic reversion to main screen if no button operation for 75 seconds at any setting screen.

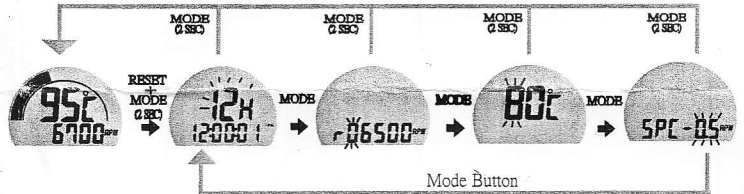

2. Press both MODE & RESET buttons for 2 seconds to go into setting screen. In setting screens, press RESET button to add the flashing digit by 1 or convert 12/24-H, press MODE button to confirm the digit setting and jump to next digit or next screen to be set. Press MODE button for 2 seconds at any setting screen to finish the setting and go to main screen.
3. It displays "12 or 24H and XX:XX:XX" symols and AM/PM if you select 12H. Operates buttons as descriptions of item 2 to finish clock setting and jump to shift RPM warning setting.
4. It displays "rXXX00 RPM". Follows the item 2 of button operation to finish the shift RPM warning setting and jump to temperature warning setting.
5. It displays "XX°C" symbol. Follows the item 2 of button operation to finish the temperature warning setting and jump to engine rotations per signal setting screen.
6. It displays "SPC-X.X RPM", the default value is 1.0; there are 4 options: 1.0, 2.0, 3.0 and 0.5. It means the numbers of engine rotation per signal. For example the value 2.0 means the engine rotate 2 turns to output a signal.
7. Press RESET button to move in loop sequence from one to another value of the 4 values. Press MODE button to confirm the setting digit.
8. Press MODE button for 2 seconds to complete the setting process and jump to main screen.

Wire Connect & RPM Sensor

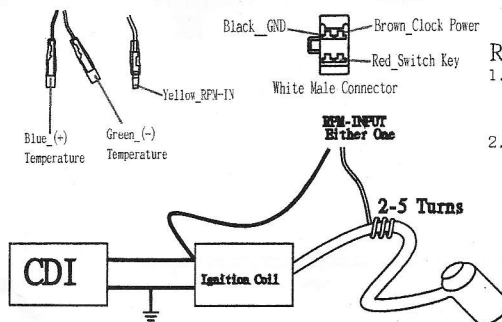

RPM Sensor Mounting:

1. Signal intensity from ignition coil varies depending on vehicle type.
2. Circles 2-5 turns around ignition coil, with more turns creating steadily stronger signal, fewer turns reating weaker signal.

A B C D E F G H

1 2 3 4 5

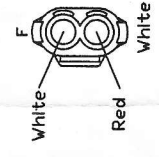
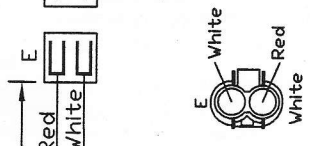
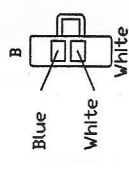
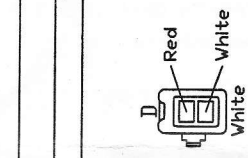
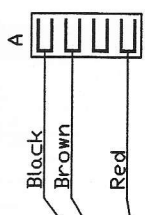
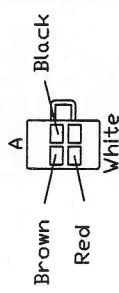
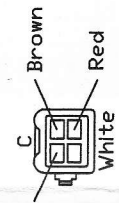
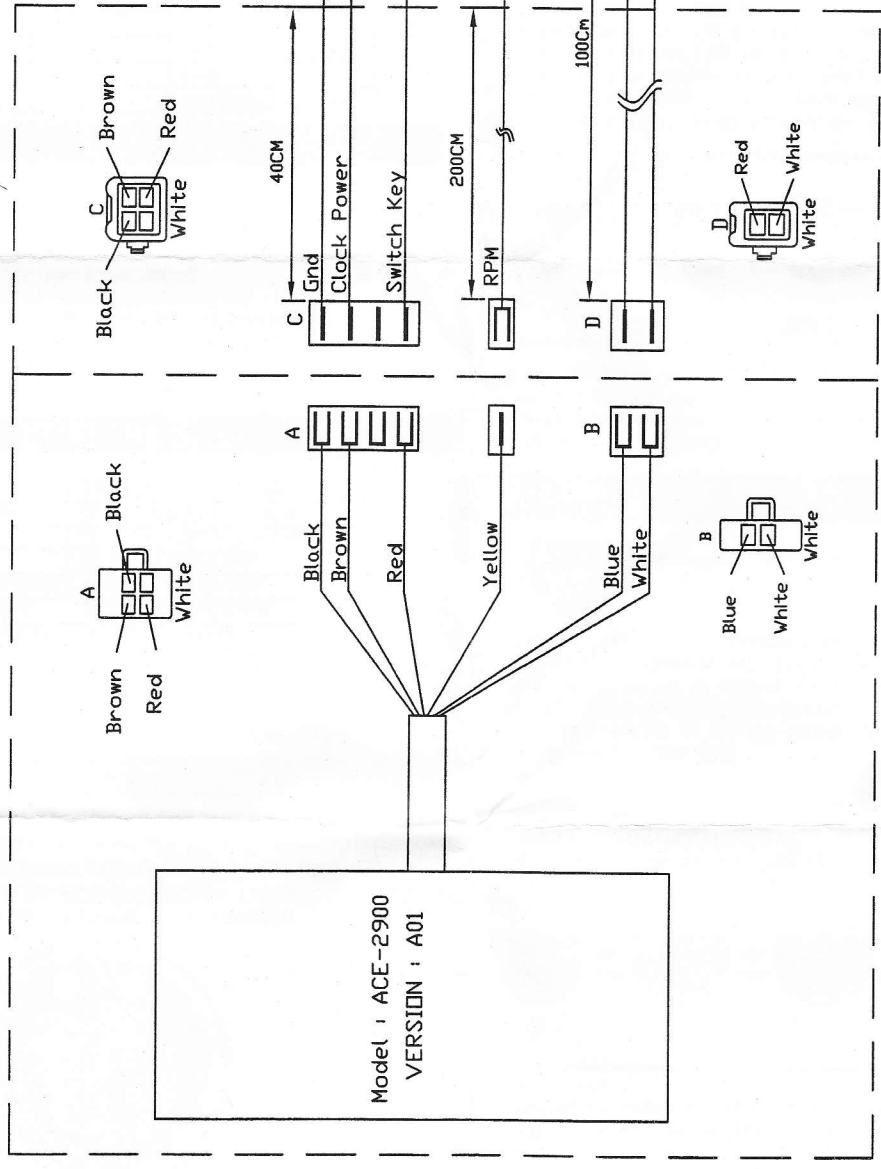
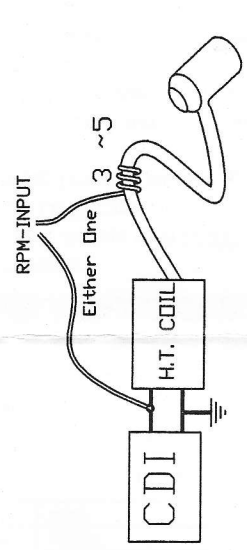

Model : ACE-2900
VERSION : A01

MODEL NO.	ACE-2900
VERSION	A01
FUR	Banditmaria
德昇電子有限公司 ACEWELL INTERNATIONAL CO., LTD.	

A B C D E F G H

1

2

3

4

5